

10/5/11

---

# PARTS MANUAL

## 100, 150, 180, 250 R - SERIES

### ROUST-A-BOUTS

---

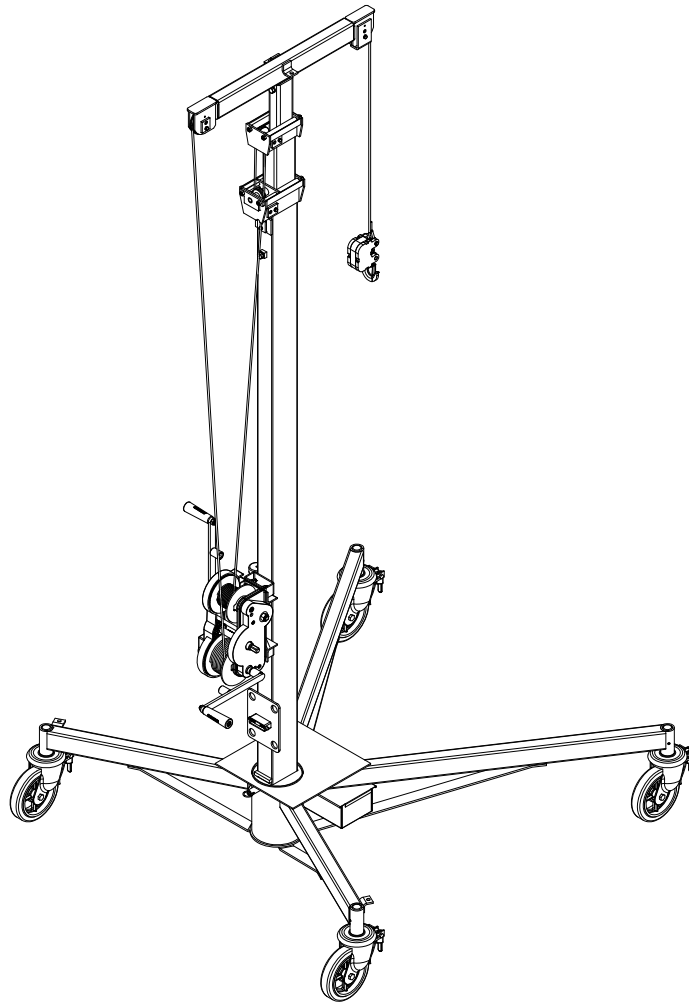

---

# SUMNER<sup>®</sup>

---

7514 Alabonson Rd.      Houston, Texas 77088      281-999-6900      281-999-6966 (fax)  
470 Collier MacMillan Drive, Unit 2&3      Cambridge, Ontario N1R 5Y7      519-623-2300      519-623-0744 (fax)  
Unit 16A Blackpole Trading Estate East Blackpole Road Worcester WR3 8SG, UK (44) 01905 458333 (44) 01905 458222 (fax)

# R-Series Roust-A-Bout Assembly

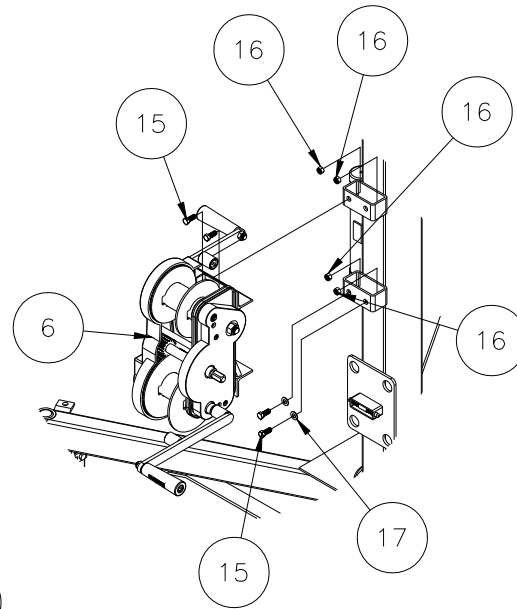
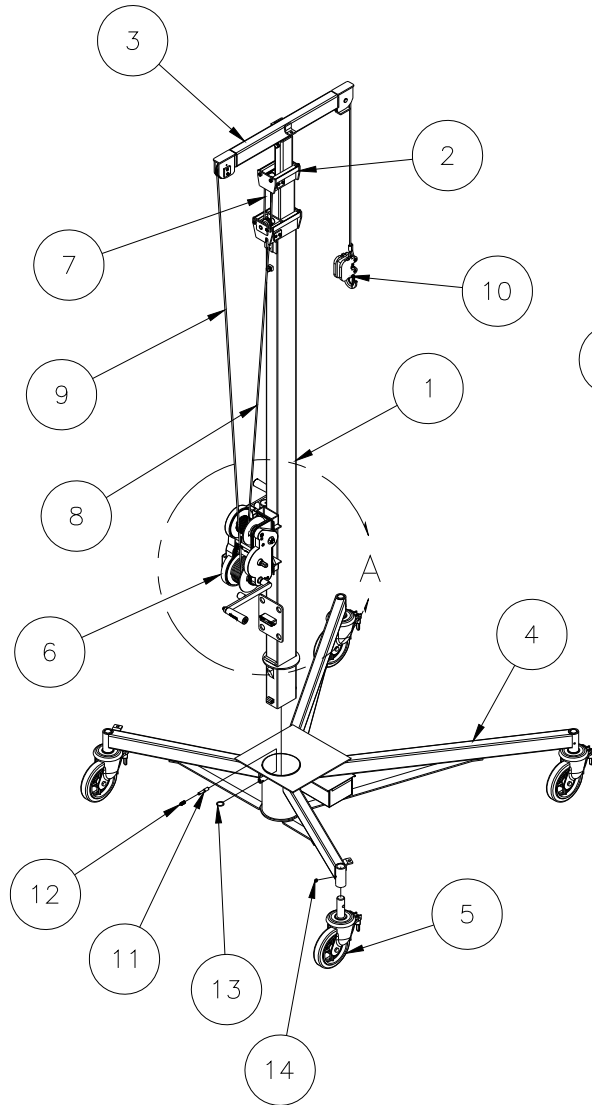

**Detail A**

17	773040	2	WASHER, FLAT 3/8
16	772355	4	NUT, INSERT LOCK 3/8-16
15	771107	4	SCREW, HHC 3/8-16 X 1
14	771460	4	SCREW, SET 3/8-16 X 3/8 CUP PT
13	775110	1	SPLIT RING 1-1/4" NICK. PLTD.
12	776212	1	SPRING, #C0480-042-1250-M
11	782510	1	PLUNGER
10	776279	1	GALV COUNTER WEIGHT, RAB
	780052	1	COUNTER WEIGHT, RAB-511
9	780051	1	LOAD LINE 55 FT. (RAB)
	780125	1	MAST ELEVATION LINE R-250
8	780122	1	MAST ELEVATION LINE R-180
	780124	1	MAST ELEVATION LINE R-100/150
	780123	1	EQUALIZING LINE R-250
7	780121	1	EQUALIZING LINE R-100/150
6	780200	1	WINCH W/LOAD LINE CS-2000
5	779001	4	CASTER SC-23-8 X 2 RT
	779989	1	BASE WELDMNT, Z & R-250, GALV
	780019	1	BASE WELDMNT Z & R-250
4	780018	1	BASE WELDMNT Z & R-180/200
	780017	1	BASE WELDMNT Z & R-150
	780016	1	BASE WELDMNT Z & R-100
	779988	1	BASE WELDMNT, Z & R-100, GALV
	780050	1	TOP MAST ASSEMBLY Z & R-250
3	780466	1	TOP MAST ASSEMBLY R-180
	780048	1	TOP MAST ASSEMBLY Z & R-100/150
	780342	1	CENTER MAST ASSEMBLY R-250
2	780450	1	CENTER MAST ASSEMBLY R-100/150
	780291	1	BOTTOM MAST ASSEMBLY R-180/250
1	780448	1	BOTTOM MAST ASSEMBLY R-100/150
Item	Part No.	Qty	Description
Parts List			

# Bottom Mast Assembly

NOTE:  
MODEL R-180 ONLY  
REPLACE ITEMS 6, 7, & 8  
WITH ITEM 22

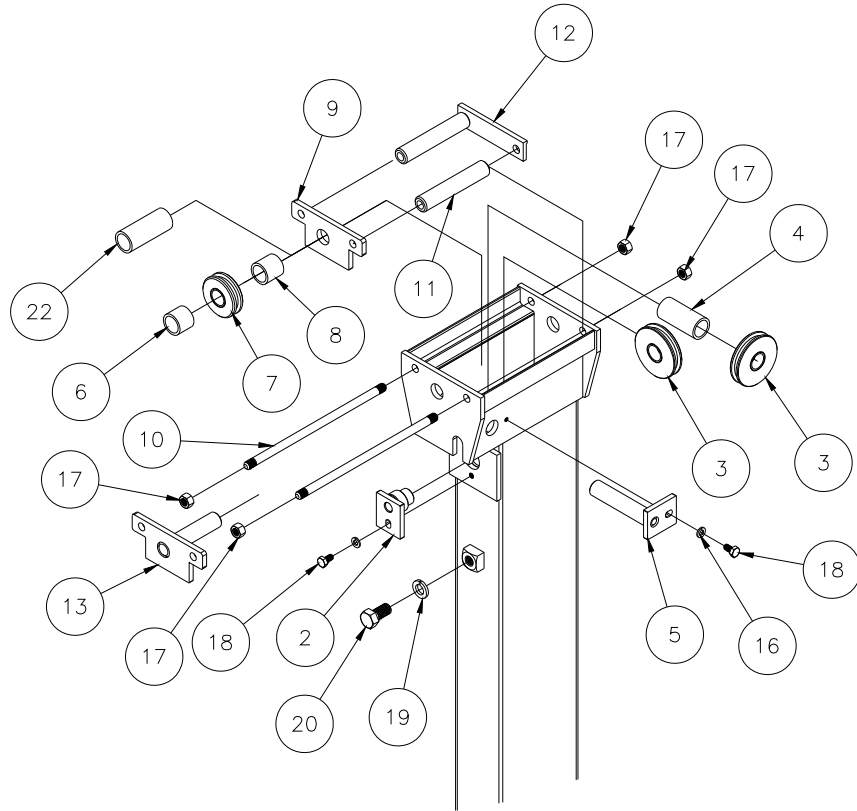

**Detail A**

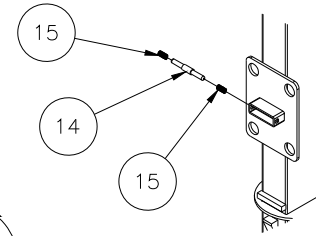

**Detail B**

22	780322	1	SEPARATOR LONG R180 ONLY
21	779905	2	CAP, 2" OD TUBE, BLACK
20	771125	1	SCREW, HHC 1/2-13 x 1
19	773590	1	WASHER, LOCK 1/2
18	771020	2	SCREW, HHC 1/4-20 x 1/2
17	772355	4	NUT, INSERT LOCK 3/8-16
16	773550	2	WASHER, LOCK 1/4
15	776067	2	SPRING, #C0480-042-1250-M
14	780335	1	HANDLE LOCK PIN, R-SERIES RAB
13	780295	1	SHAFT STAY WELDMENT, R-SERIES
12	780027	1	WEAR PLATE, BM RAB-206 Z-27
11	780021	2	ROLLER, BM RAB-223
10	780022	2	ROLLER SHAFT, BM RAB-224
9	780090	1	B.M. FRONT SHAFT PLATE RAB 204
8	780293	1	SEPARATOR, BM R-SERIES RAB
7	780297	1	SHEAVE ASSY, 2" R-SERIES RAB
6	780023	1	SEPARATOR RAB 318 .90 LG.
5	780198	1	SHAFT WELDMENT BM SIDE Z-29
4	780292	1	SEPARATOR, BM R-SERIES RAB
3	780299	2	EQUALIZING PULLEY ASSEMBLY
2	780452	1	SHAFT WELDMENT, R-SERIES RAB
1	780285	1	BOTTOM MAST WELDMENT R-180/250 GALV.
	780290	1	BOTTOM MAST WELDMENT R-180/250
	780328	1	BOTTOM MAST WELDMENT R-100/150 GALV.
	780447	1	BOTTOM MAST WELDMENT R-100/150
Item	Part No.	Qty	Description
Parts List			

# Center Mast Assembly

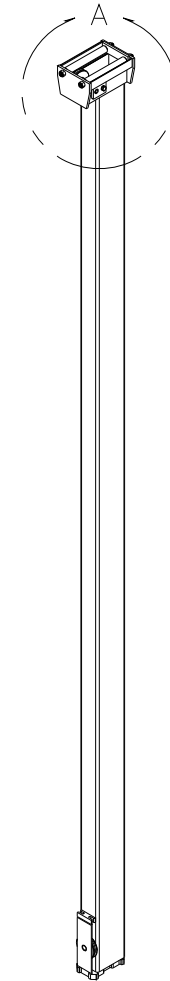
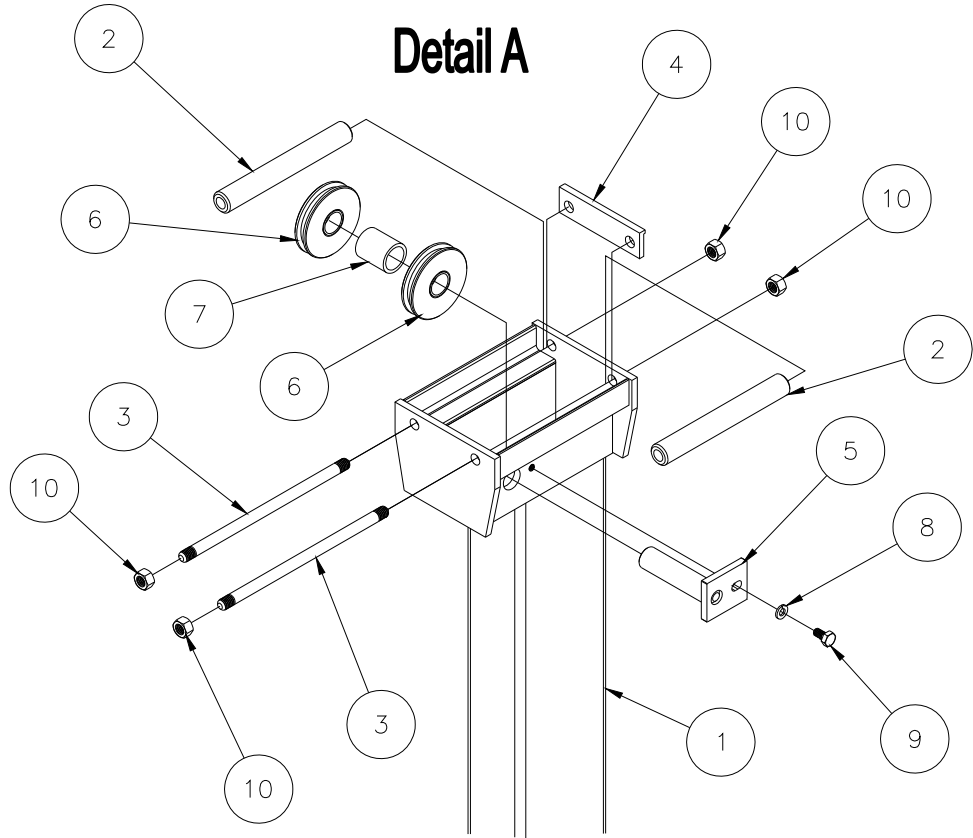

10	772355	4	NUT, INSERT LOCK 3/8-16
9	771020	1	SCREW, HHC 1/4-20 X 1/2
8	773550	1	WASHER, LOCK 1/4
7	780343	1	SEPARATOR, CM R-100/150
6	780299	2	EQUALIZING PULLEY ASSY. R-100
5	780036	1	SHAFT, EQUALIZING RAB
4	780035	1	WEAR PLATE, CM RAB-304
3	780334	2	ROLLER SHAFT, CM R-100/150
2	780349	2	ROLLER, CENTER MAST R-100/150
1	780327	1	CENTER MAST WELDMNT R-250 GALV.
	780341	1	CENTER MAST WELDMNT R-250
	780329	1	CENTER MAST WELDMNT R-100/150 GALV.
	780449	1	CENTER MAST WELDMNT R-100/150
Item	Part No.	Qty	Description
Parts List			

10/5/11

# Top Mast Assembly

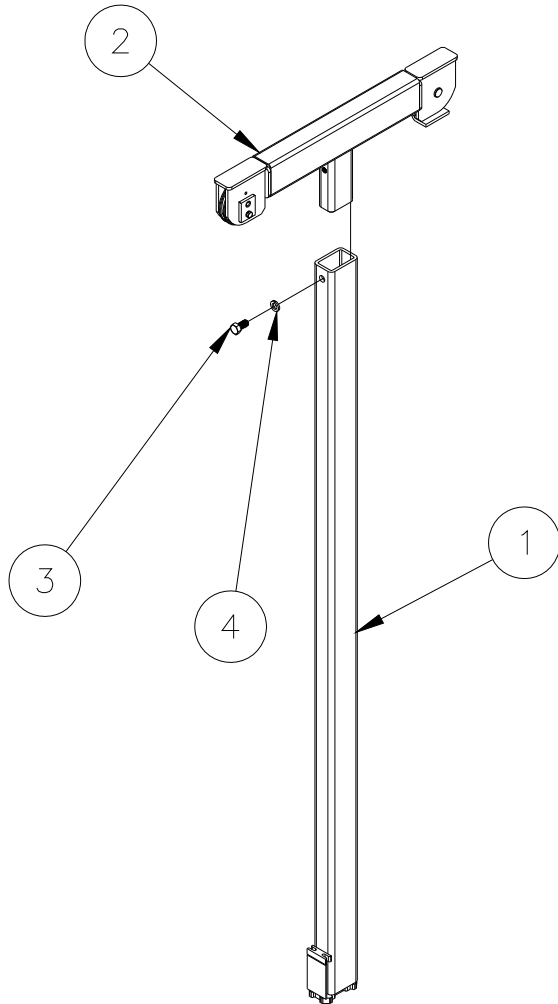

4	771125	1	SCREW, HHC 1/2-13 X 1
3	773590	1	WASHER, LOCK 1/2
2	780463	1	TEE HEAD ASSEMBLY Z&R-250
	780464	1	TEE HEAD ASSEMBLY Z&R-180
	780465	1	TEE HEAD ASSEMBLY Z&R-100/150
1	779987	1	TOP MAST WELDMENT Z&R-250, GALV.
	780007	1	TOP MAST WELDMENT Z&R-250
	780223	1	TOP MAST WELDMENT Z&R-180
	779986	1	TOP MAST WELDMENT Z&R-100/150, GALV.
	780005	1	TOP MAST WELDMENT Z&R-100/150
Item	Part No.	Qty	Description
Parts List			

# Tee Head Assembly

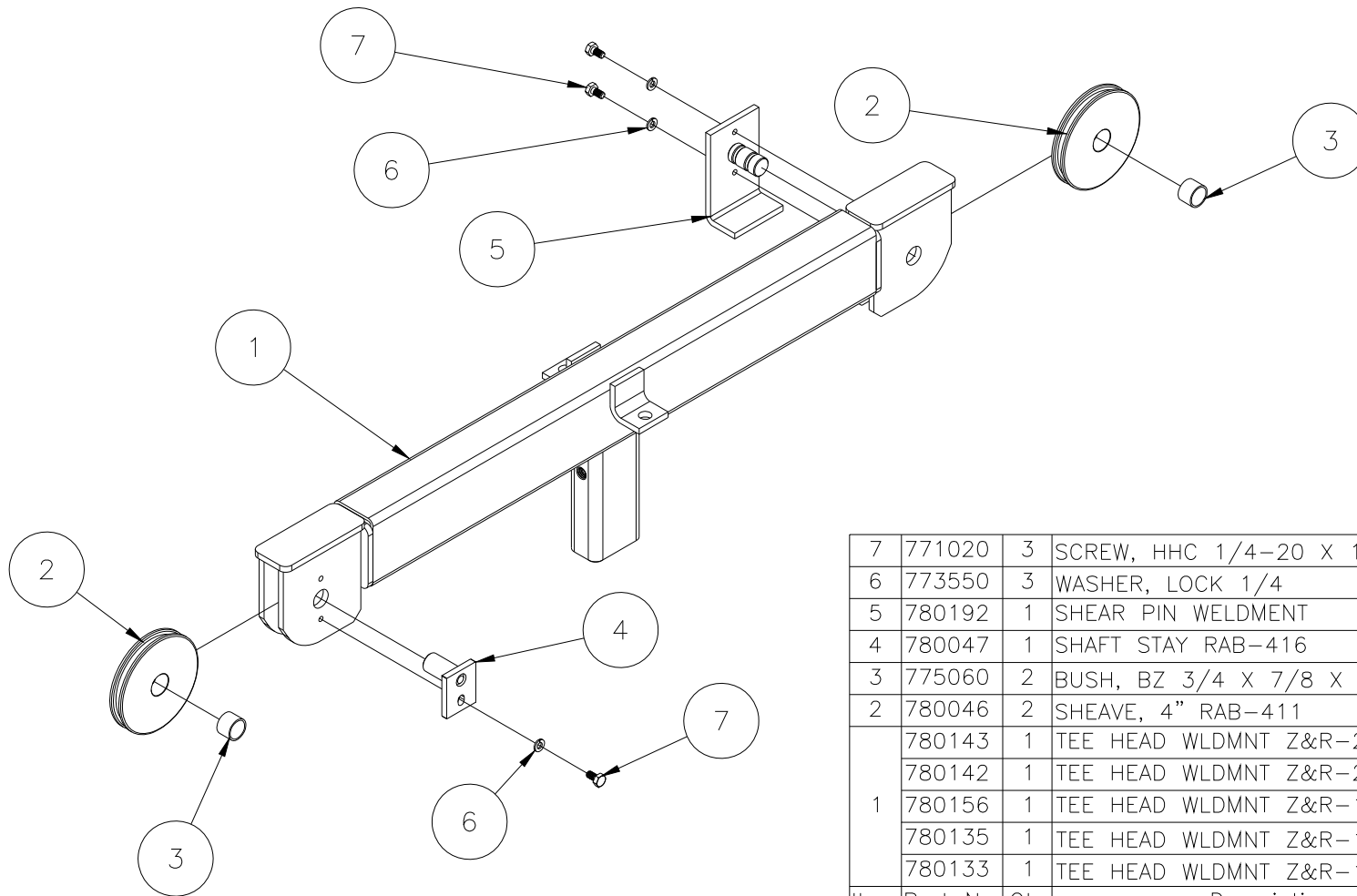

7	771020	3	SCREW, HHC 1/4-20 X 1/2
6	773550	3	WASHER, LOCK 1/4
5	780192	1	SHEAR PIN WELDMENT
4	780047	1	SHAFT STAY RAB-416
3	775060	2	BUSH, BZ 3/4 X 7/8 X 5/8
2	780046	2	SHEAVE, 4" RAB-411
1	780143	1	TEE HEAD WLDMNT Z&R-250, GALV.
	780142	1	TEE HEAD WLDMNT Z&R-250
	780156	1	TEE HEAD WLDMNT Z&R-180
	780135	1	TEE HEAD WLDMNT Z&R-100/150, GALV.
	780133	1	TEE HEAD WLDMNT Z&R-100/150
Item	Part No.	Qty	Description
Parts List			

# Cable Reeving Diagram

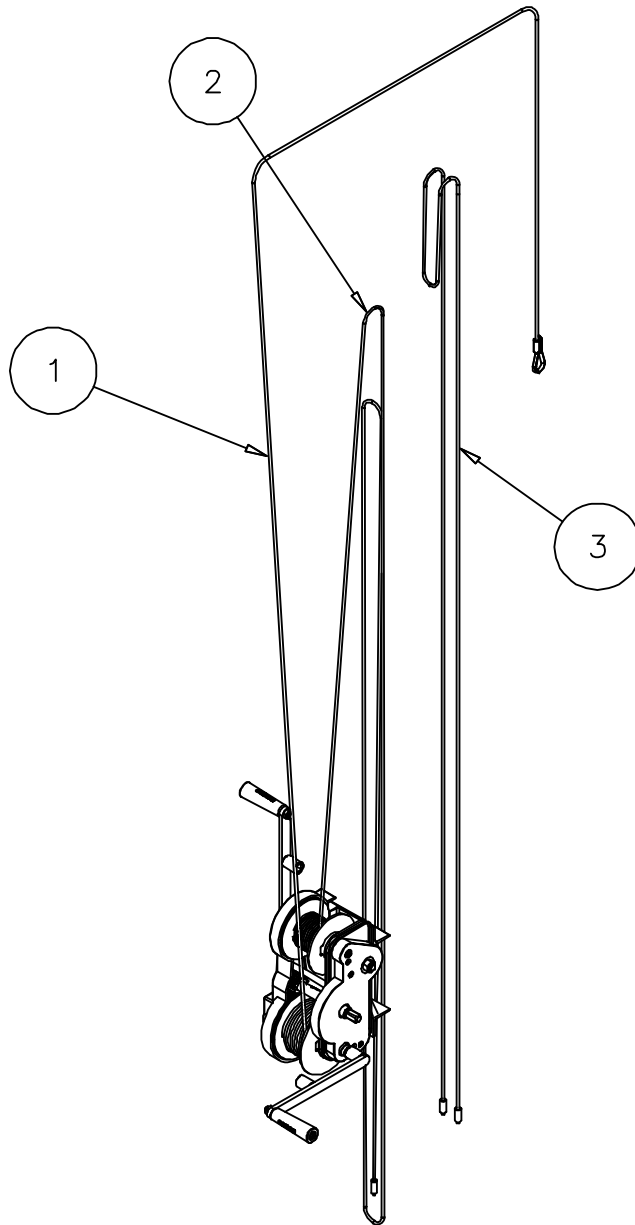

3	*	1	EQUALIZING LINE	*
2	*	1	MAST ELEVATING LINE	*
1	780051	1	LOAD LINE 55 FT. (RAB)	
Item	Part No.	Qty	Description	
Parts List				

\* SEE APPLICATION CHART

APPLICATION CHART				
ITEM	MODEL 100	MODEL 150	MODEL 180	MODEL 250
2	780124	780124	780122	780125
3	780121	780121	N/A	780123

# CS2000 Winch Assembly

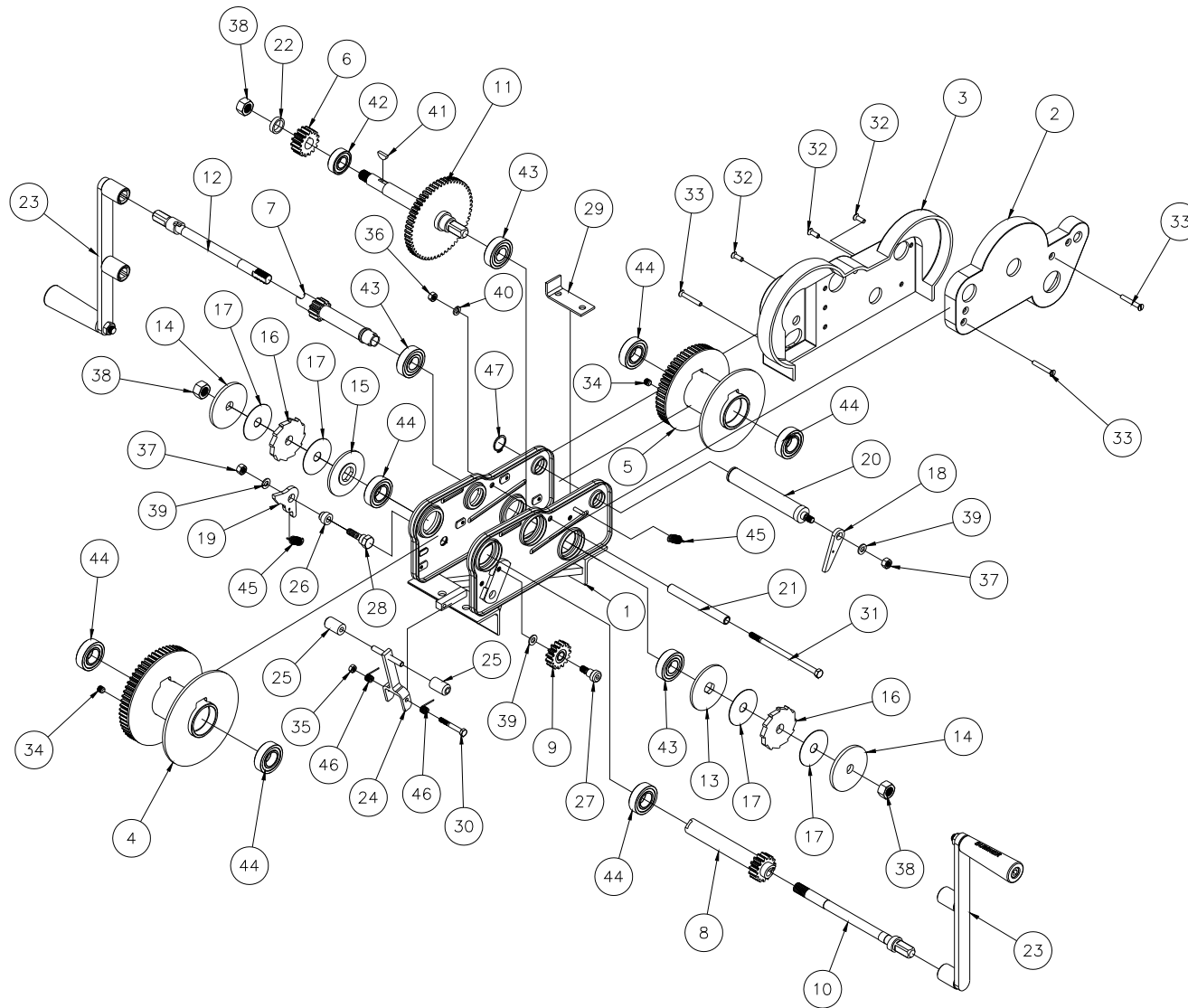

47	776083	1	RETAINING RING 1"
46	775240	2	SUREEL SPRING
45	775230	2	SPRING, RACHET DOG
44	775220	6	BEARING 1"
43	775210	3	BEARING 7/8"
42	775200	1	BEARING 3/4"
41	774075	1	WOODRUFF KEY 3/16 X 3/4
40	773560	1	WASHER, LOCK 5/16
39	773042	3	WASHER, FLAT 5/16
38	772375	3	NUT, INSERT LOCK 5/8-18
37	772355	2	NUT, INSERT LOCK 3/8-16
36	772351	1	NUT, INSERT LOCK 5/16-18
35	772050	1	NUT, HEX 1/4-20
34	771460	2	SCREW, SET 3/8-16 X 3/8
33	771286	3	SCREW, FLAT HD 1/4-20 X 1-3/4
32	771284	3	SCREW, FLAT HD 1/4-20 X 3/4
31	771051	1	SCREW, HHC 5/16-18 X 6
30	771035	1	SCREW, HHC 1/4-20 X 2
29	780174	1	ROPE GUARD ANGLE
28	780612	1	RACHET STUD
27	780496	1	SCREW, SHOULDER 1/2 X 5/8
26	780251	1	RACHET DOG SPACER
25	780249	2	ROLLER
24	780248	1	LEVER ASSEMBLY
23	780244	2	WINCH HANDLE ASSEMBLY
22	780225	1	LOAD PINION SPACER
21	780221	1	SPREADER BAR
20	780220	1	HOIST DRUM SHAFT
19	780217	1	LOAD RACHET DOG
18	780216	1	HOIST RACHET DOG
17	780215	4	BRONZE BRAKE DISC
16	780214	2	BRAKE RACHET
15	780213	1	LOAD BRAKE DISC
14	780212	2	BRAKE DISC
13	780211	1	HOIST BRAKE DISC
12	780210	1	HOIST SHAFT
11	780209	1	HIGH SPEED SHAFT
10	780208	1	LOW SPEED SHAFT
9	780207	1	IDLER GEAR
8	780206	1	LOW SPEED PINION
7	780205	1	HOIST DRUM PINION
6	780204	1	LOAD DRUM PINION
5	780203	1	HOIST DRUM ASSEMBLY
4	780202	1	LOAD DRUM ASSEMBLY
3	780603	1	COVER, LARGE
2	780602	1	COVER, SMALL
1	780601	1	HOUSING WELDMENT
Item	Part No.	Qty	Description
Parts List			

# CS2000 Winch Handle

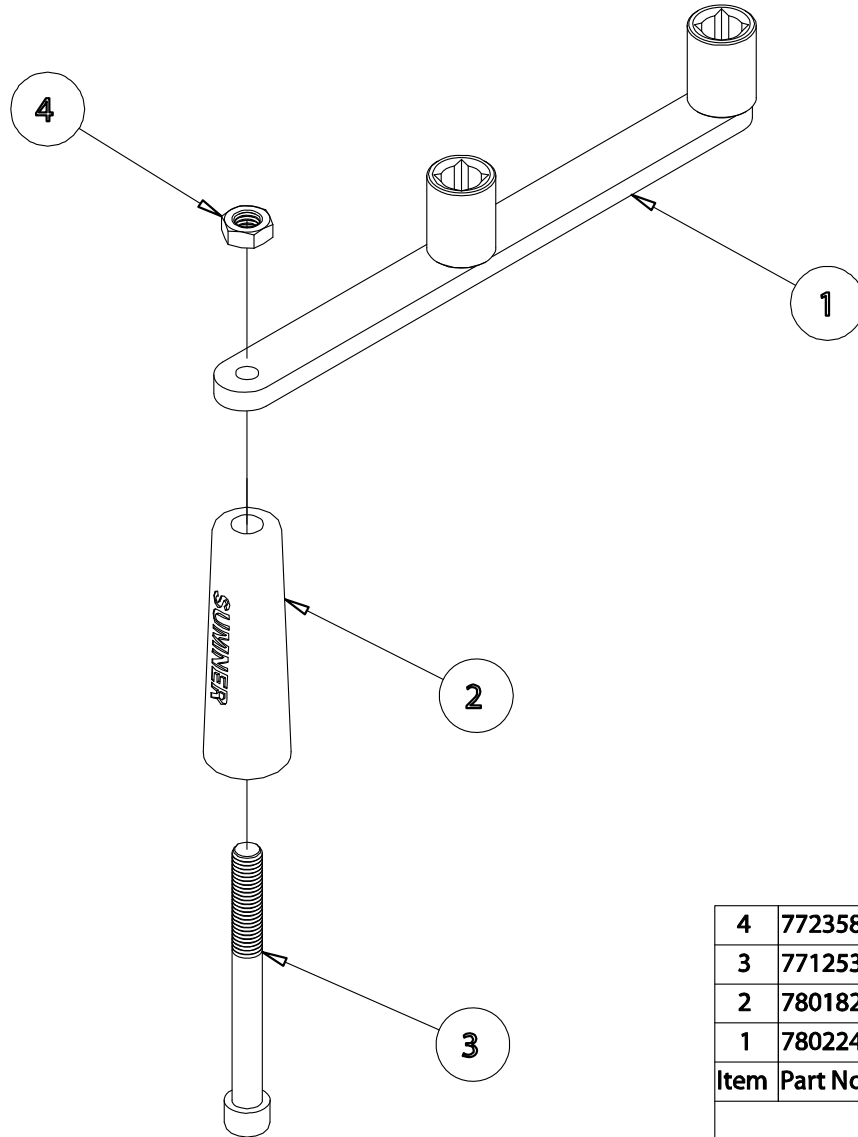

4	772358	1	NUT, HEX JAM LOCK 1/2-13
3	771253	1	SCREW SHC 1/2-13 x 4-3/4
2	780182	1	WINCH HANDLE SLE EVE
1	780224	1	WINCH HANDLE WELDMENT
Item	Part No.	Qty	Description
Parts List			

10/5/11

## 778387 – RAB LABEL INSTALLATION KIT

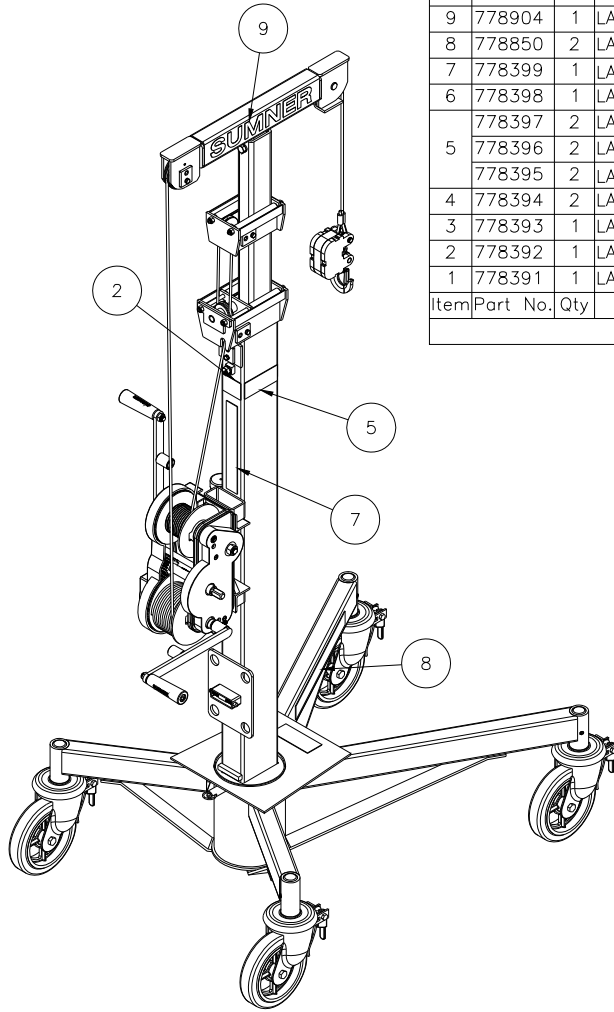

11	778933	1	LABEL ROUST-A-BOUT 2-1/4 X 14
10	778906	1	LABEL, OPERATOR MANUAL READ BEFORE
9	778904	1	LABEL, SUMNER RAB
8	778850	2	LABEL, DO NOT STAND UNDER LOAD
7	778399	1	LABEL, SERIAL NUMBER/CE
6	778398	1	LABEL, WARNING INSTRUCTIONS
5	778397	2	LABEL, MODEL NUMBER R250
	778396	2	LABEL, MODEL NUMBER R180
4	778395	2	LABEL, MODEL NUMBER R100/R150
	778394	2	LABEL, SHEAR PIN
3	778393	1	LABEL, BASE LOCK
2	778392	1	LABEL, CAUTION MAST STOP
1	778391	1	LABEL, CAUTION DO NOT WELD
Item	Part No.	Qty	Description
Parts List			

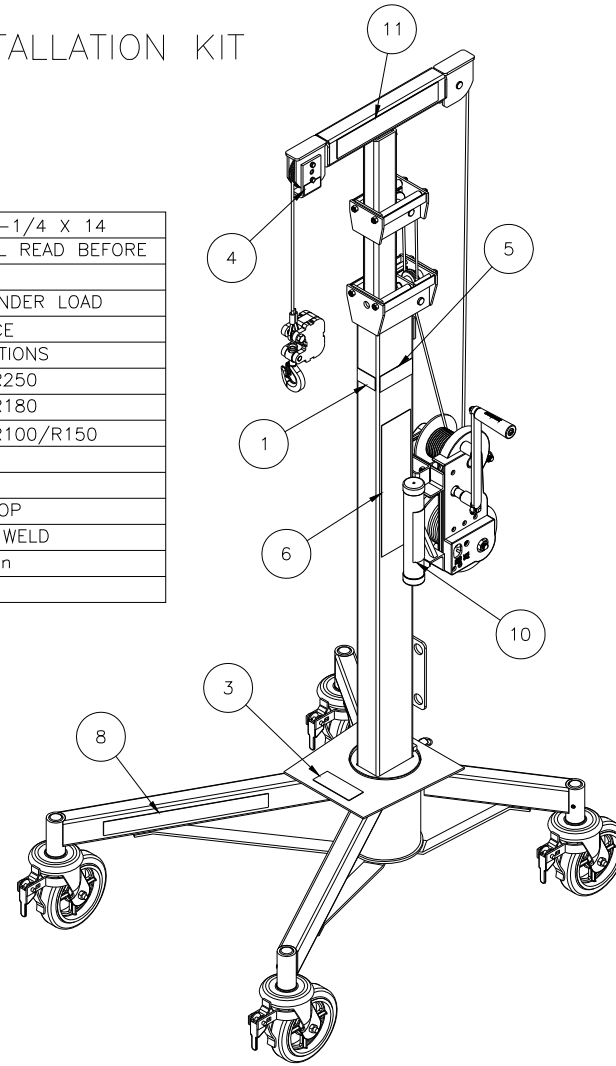

10/5/11

- 781060 – TEE HEAD EXT. ASSY. 100/150
- 781061 – TEE HEAD EXT. ASSY. 180
- 781062 – TEE HEAD EXT. ASSY. 250

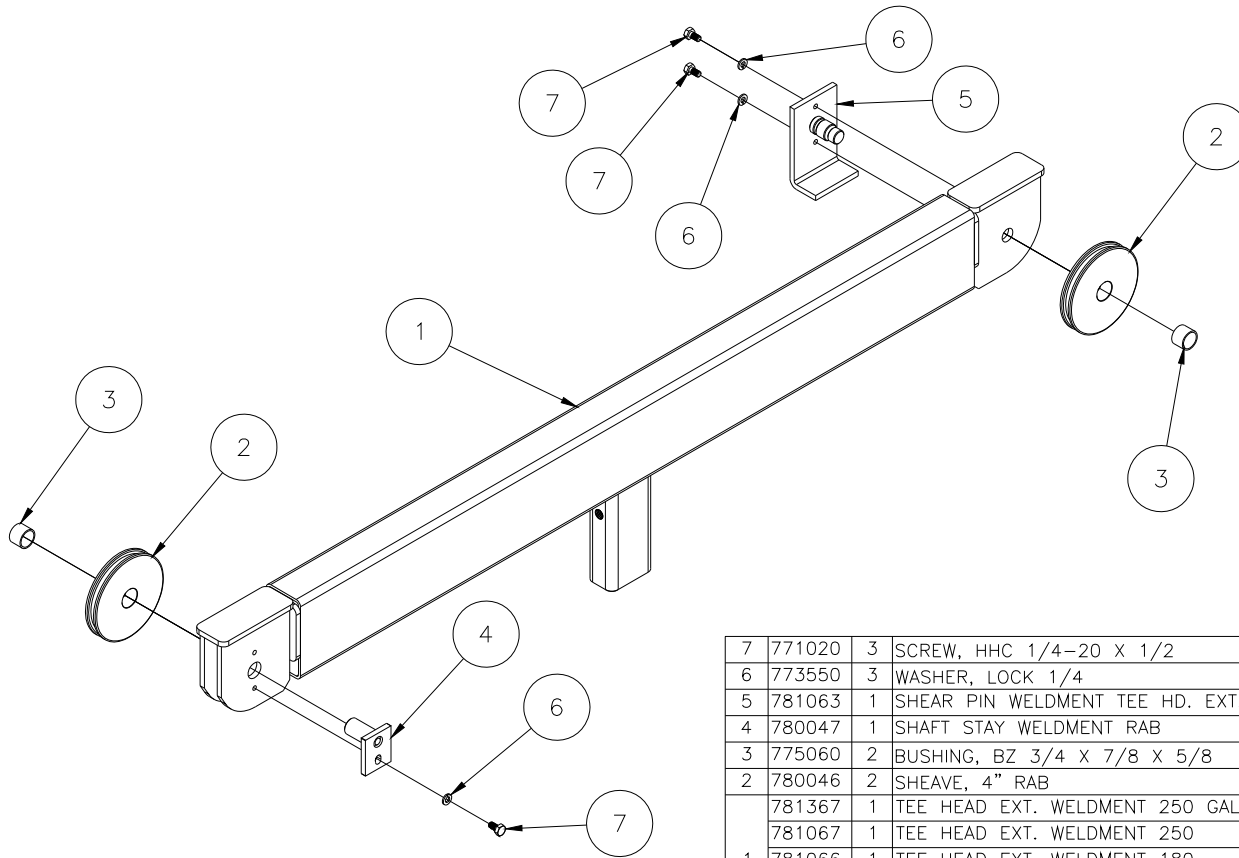

7	771020	3	SCREW, HHC 1/4-20 X 1/2
6	773550	3	WASHER, LOCK 1/4
5	781063	1	SHEAR PIN WELDMENT TEE HD. EXT.
4	780047	1	SHAFT STAY WELDMENT RAB
3	775060	2	BUSHING, BZ 3/4 X 7/8 X 5/8
2	780046	2	SHEAVE, 4" RAB
1	781367	1	TEE HEAD EXT. WELDMENT 250 GALV.
	781067	1	TEE HEAD EXT. WELDMENT 250
	781066	1	TEE HEAD EXT. WELDMENT 180
	781365	1	TEE HEAD EXT. WELDMENT 100/150 GALV.
	781065	1	TEE HEAD EXT. WELDMENT 100/150
Item	Part No.	Qty	Description
Parts List			